

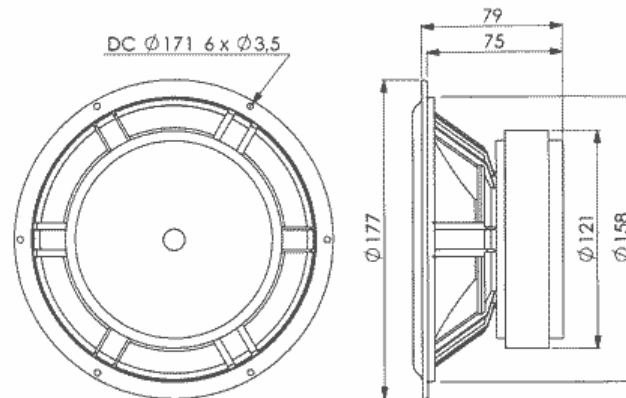

18W/8546-00

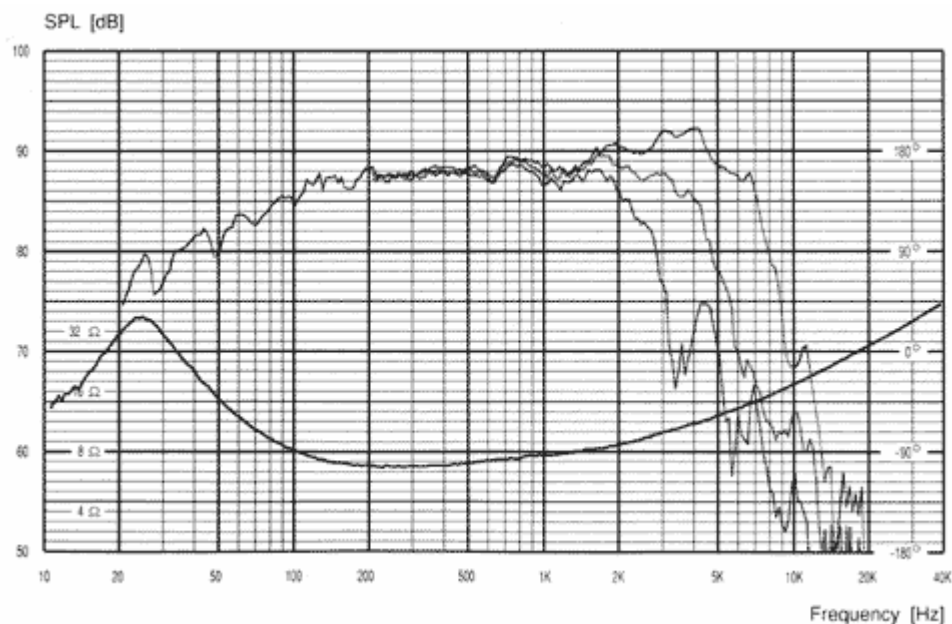

Characteristic sensitivity (2.83V / 1m)	: 88 dB
Recommended frequency range	: 22 - 4000 Hz
Free air resonance frequency, f_s	: 22 Hz
DC resistance, R_e	: 5.5 ohm
Voice coil inductance, L_e	: 0.4 mH
Effective piston area, S_d	: 145 cm ²
Moving mass incl. air, m_d	: 18.5 g
Mechanical loss, R_m	: 1.5 Ns/m
Force factor, BL	: 8.0 Tm
Equivalent volume, V_{as}	: 84 ltr.
Mechanical Q-factor, Q_{ms}	: 1.7
Electrical Q-factor, Q_{es}	: 0.22
Total Q-factor, Q_{ts}	: 0.19
Excursion, lin./max.	: $\pm 6.5 / \pm 10$ mm
Voice coil diameter	: 42 mm
Rated power handling	: 100 W
Net weight	: 2.4 kg



Frequency response: 2.83V / 1m