



Application Note *L26ROY*

A high-end subwoofer with a 10" driver and a passive radiator



Drive units:

The woofer is the [SEAS Design D1001-04 L26ROY](#).

The target for this product was to achieve good low-frequency extension in a relatively small enclosure volume. Finding the right balance between moving mass, suspension stiffness and motor force factor is important, and this is directly influenced by component selection and design.

To transfer the motion of the voice-coil to the surrounding air we need a very stiff cone in this application. The aluminum cone used in the L26ROY is very rigid and is ideal for this task.

This cone makes the loudspeaker free from resonances in a very wide frequency range, so the use of this driver is not limited to a subwoofer. It will even perform extremely well in a 3-way speaker. The cone break-up starts at about 2.5 kHz, so a crossover frequency up to 500Hz should be possible with a passive filter.

The L26ROY use a long overhung 2-layer voice coil, and together with the copper cap over the pole piece this results in very low inductance and very little problems with inductance modulation. The measurement below is done with the Klippel LSI module and show inductance over a wide excursion range.

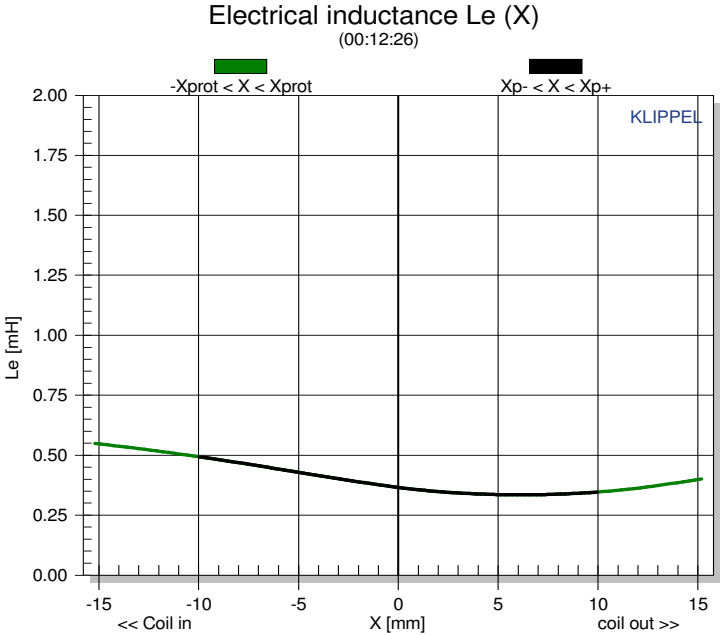

To get the force factor we need to achieve the right T/S parameters, we need an extremely large magnetsystem when using a 2-layer voice coil. The driver is very heavy and must be securely fastened to the enclosure. The Klippel LSI measurements show us that we have a very linear motor. The force factor is very symmetric due to the FEA optimized magnetic circuit, and it has only decreased by 20% when the voice coil has been displaced by 14mm in one direction.

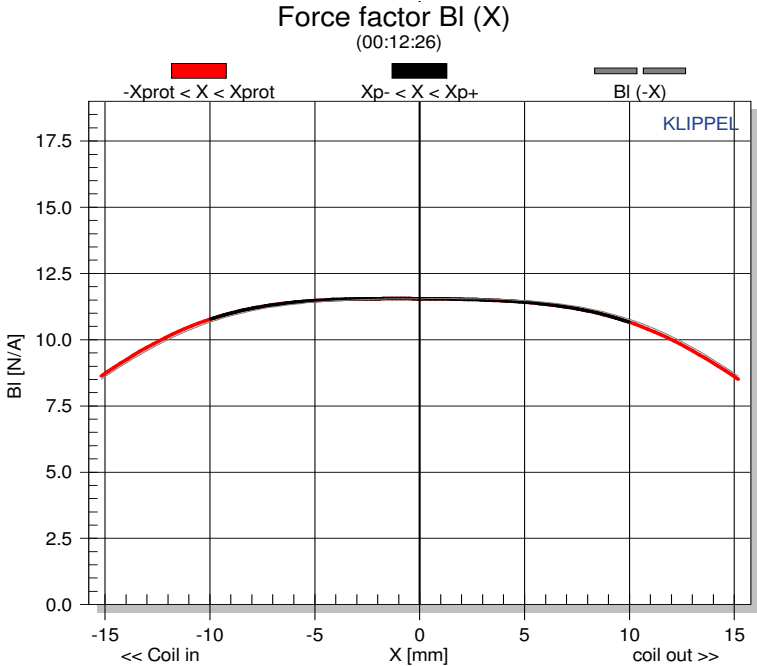

The suspension components have also been optimized by the use of modern FEA software to allow for very long excursion, while keeping the voice coil centered in the air-gap. Again, the Klippel LSI measurements confirm that the simulation has been successfully converted to a really good performing product.

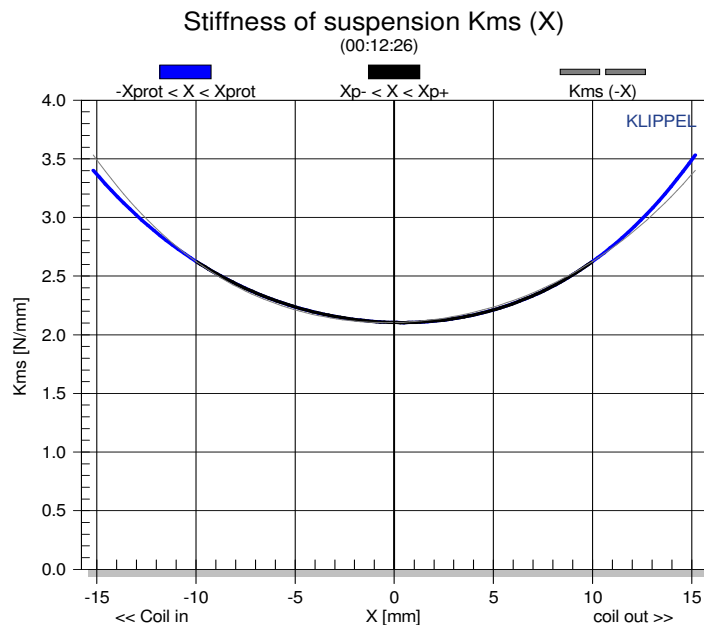

The [D1003 - SL26R](#) passive radiator is very much based on the L26ROY. The same cone and dustcap, and very similar suspension components make this the perfect match in the application we will describe below.

When designing a small vented box with a very low Helmholtz resonance frequency you soon find that it's difficult to fit the reflex port inside the box without reducing the area of the port so much that you get problems with port noise. Smaller port diameter leads to high air-velocity in the port. High air-velocity can cause audible turbulence and whistling noise when playing certain program material with loud low-frequency content. The solution to this problem is a passive radiator.

This solution is more expensive than the common reflex port, but when comparing the completely noise-free operation of the passive radiator to the chuffing and whistling reflex port, there is no doubt that the critical listener will prefer the passive radiator subwoofer.



Box design:

The simulated half-space response of the L26ROY with the SL26R passive radiator in a 40 liter box predicts a resonance frequency for the passive at 25Hz. With a low-pass filter commonly used in a subwoofer application, the -3dB point for the system is at 26Hz, and -10dB is at 21Hz.

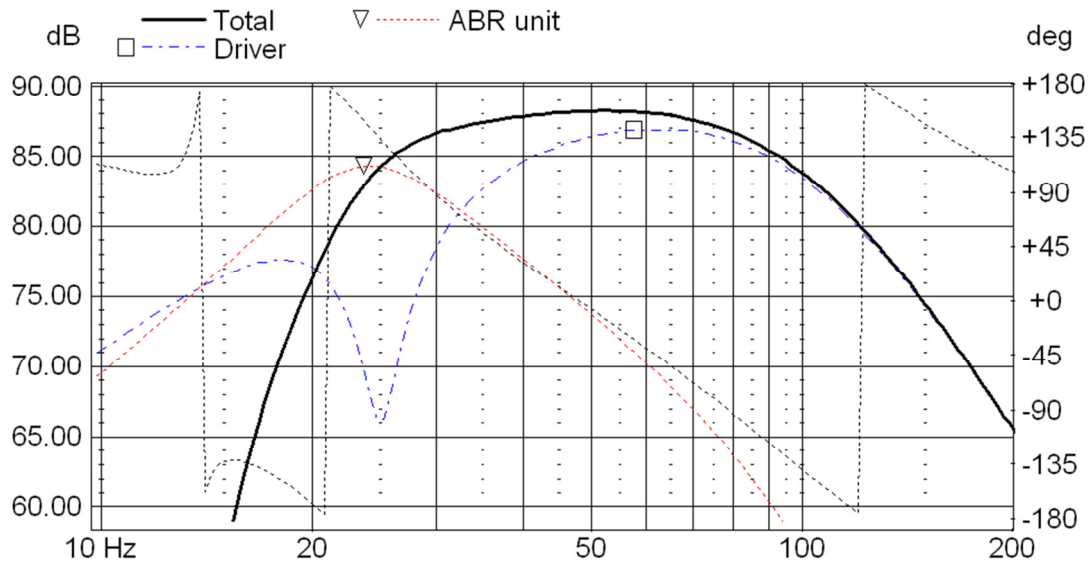

We have chosen a cubic form for this box to keep the internal standing waves well above the subwoofers operating range. The drawing also shows a separate sub-enclosure for a plate amplifier. This is important to avoid air leakage through the adjustment pots, connectors and other holes in the plate amp. Such holes will cause annoying air-noise. The volume of this enclosure is 6 liters. The dimensions for the amplifier box is not shown, as this may vary for different type of amplifiers.

Alternative box design:

In the case of a bass-reflex enclosure of the same cabinet size, a port with an ID of 7cm would have to be 38cm long in order to achieve a Helmholtz resonance at 25Hz. This leaves only 1cm to the back wall if a straight tube is used, so we don't recommend this.

Instead, we recommend increasing the cabinet size to 50 liters.

With a port diameter of 7cm, the length should be 30cm in order to have a Helmholtz resonance at 25Hz.

In a sealed box application the L26ROY could be used in a 20 liter box to have a Q_{tc} of 0.707. The -3 dB point would be 54Hz, and the -10 dB point is at 30 Hz.

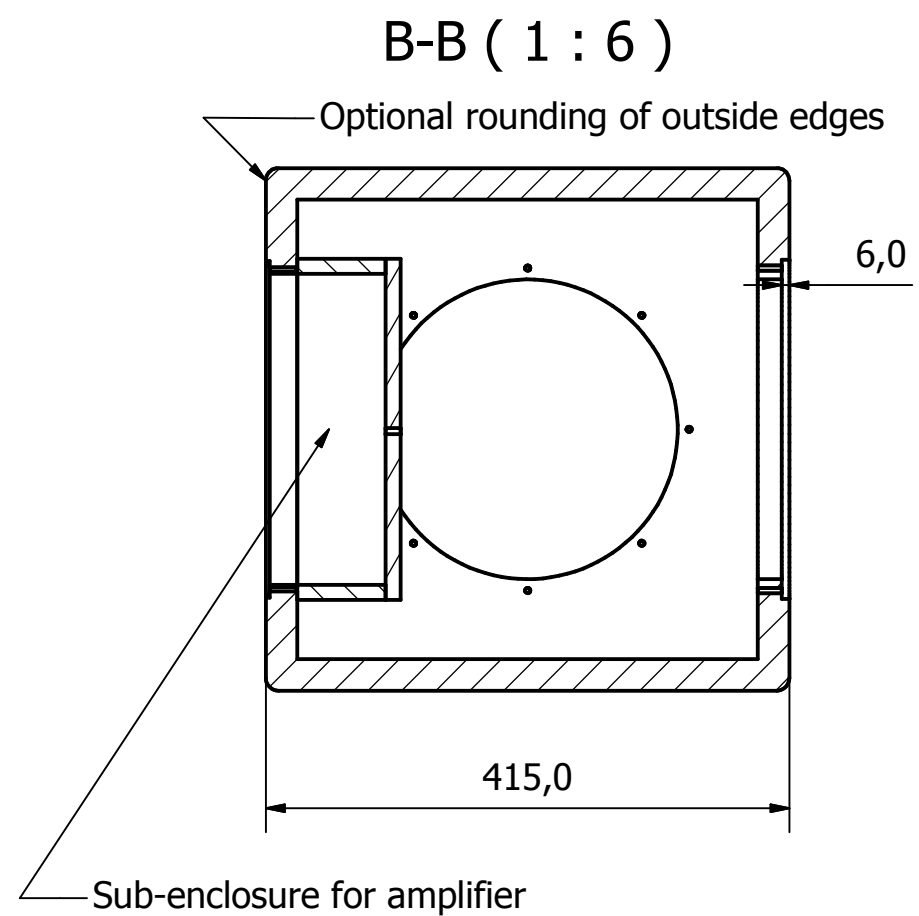
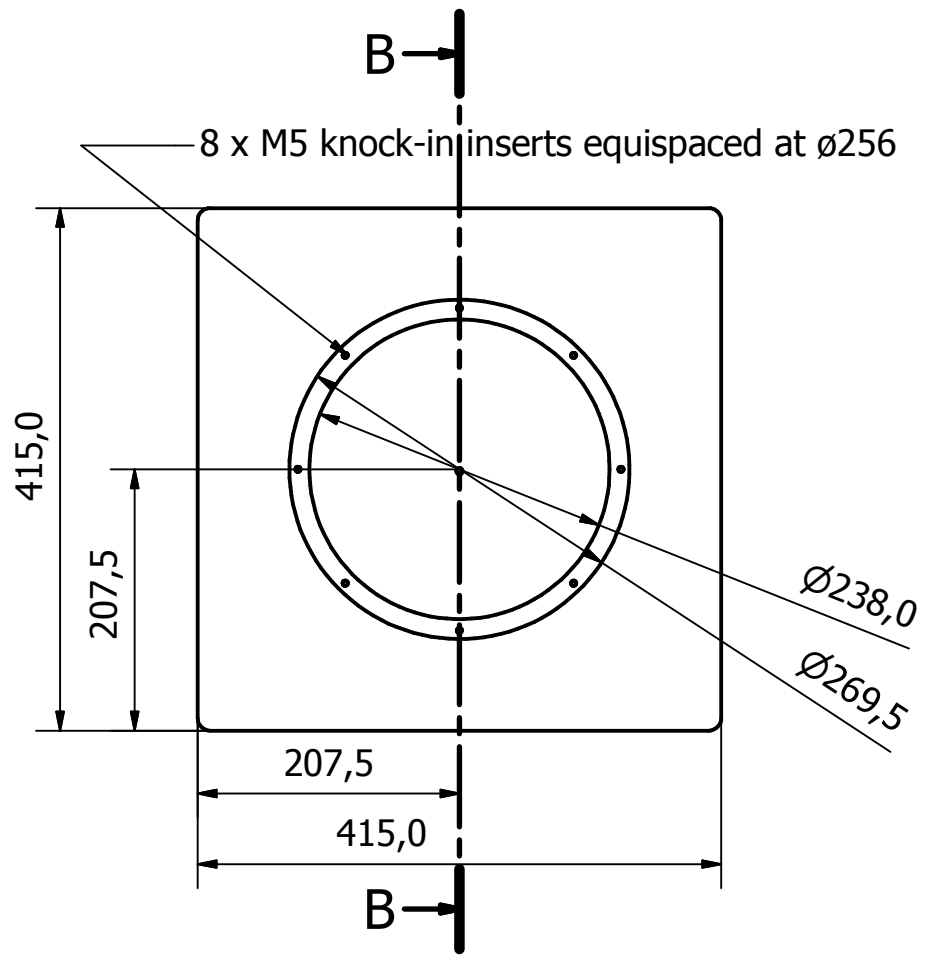

Material: 25mm MDF

Designed by bidland	Checked by	Approved by	Date	Date 03.11.2010	
			ROY-sub	Edition	Sheet 1 / 1